

# Round Bore Series With Spherical Outer Ring - Relubricable Type

## GW 209PPB12

Round Bore Series With Spherical Outer Ring - Relubricable Type

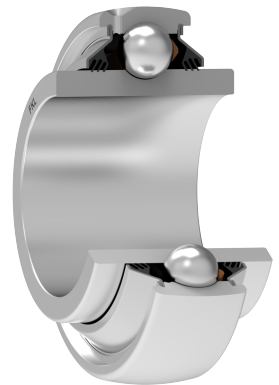
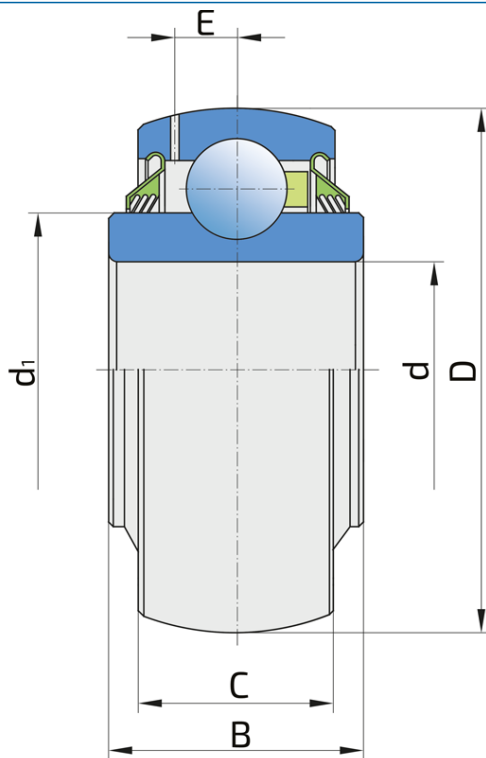

### Technical Specification

d	Bore diameter	44.83 mm
D	Outside diameter	85 mm
B	Width inner ring	42.85 mm
C	Width outer ring	22 mm
d1	Outer diameter inner ring	56.6 mm
E	Distance from raceway centre to the hole for lubrication	6.5 mm
C <sub>dyn</sub>	Dynamic load rating	32.5 kN
C <sub>o</sub>	Static load rating	20.4 kN
kg	Mass	0.68 kg

## Sealing

---

### T SEAL / T SEAL (2T)

3-lip seal on the both side of the bearing, provides equal protection against contamination. Recommended for application where the possibility of contamination is the same on the both side.

